

1. MAG焊电弧调节时间变长
2. 富氢气焊无推力电流
3. TIG焊无推力电流, 无起弧电流

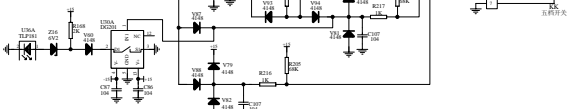

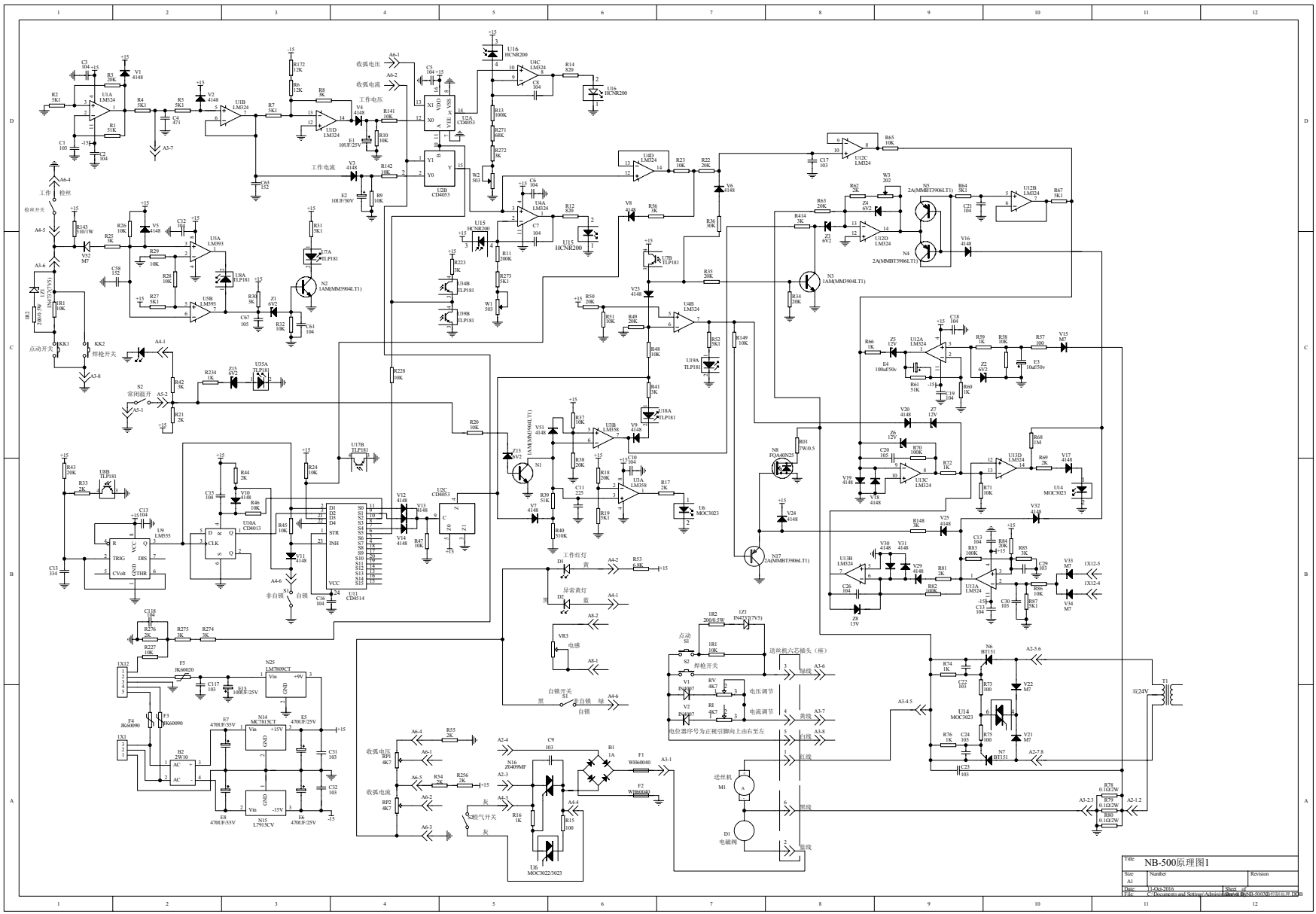

Title: NB-500原理图
 No. AI
 Date: 1994-2016
 Drawn by: C:\Programs and Schems\Adm\Draw\BDS\20030101\9117.DWG
 Revisions:

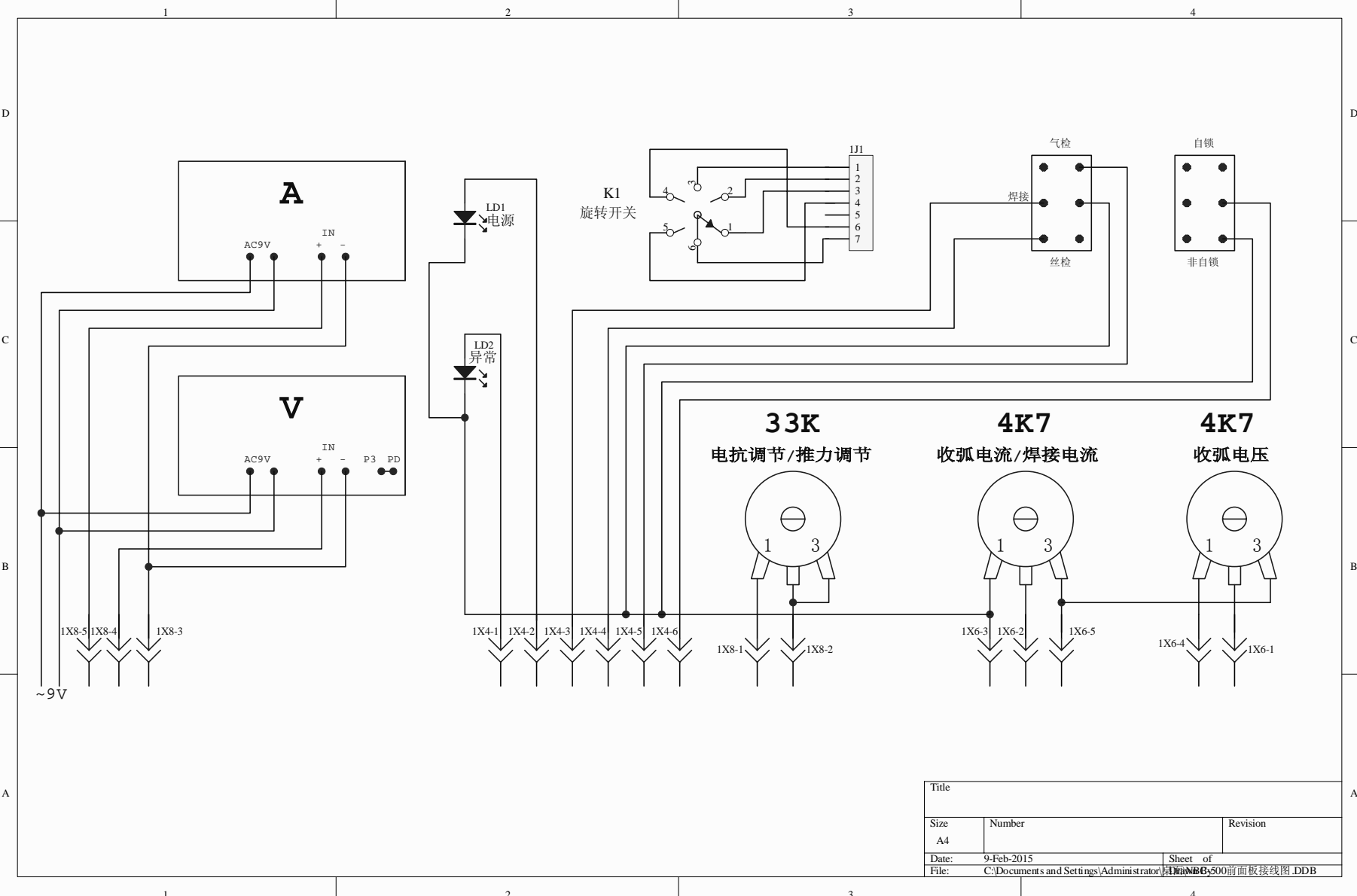

Title		
Size	Number	Revision
A4		
Date:	9-Feb-2015	Sheet of
File:	C:\Documents and Settings\Administrator\桌面\HMBB500前面板接线图.DDB	

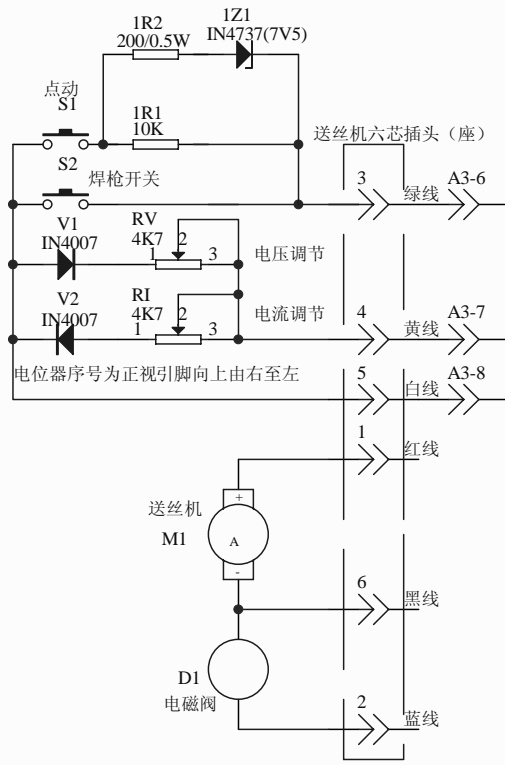

Title		
Size A4	Number	Revision
Date: 6-Dec-2016	File: C:\Documents and Settings\Administrator	Sheet of 同轴电焊送丝机接线说明.DDB